

## PRO-CSW1000 10" Car Subwoofer

Your RadioShack PRO-CSW1000 10" Car Subwoofer lets you increase the bass response of your vehicle's sound system. When mounted inside an enclosure, your sub-woofer's high-output, low-distortion design provides quality, bass sound reproduction. The subwoofer's long-travel voice coil lets it handle high input power with ease.

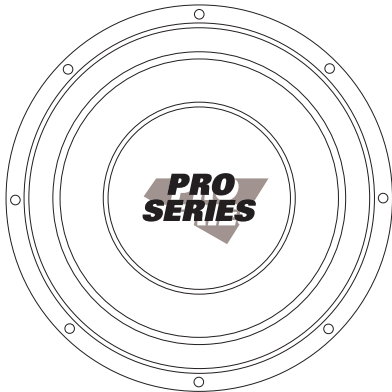

**Note:** To connect the subwoofer to your stereo amplifier's wires, you need 2 banana plugs such as Cat. No. 278-306 (not supplied).

### CHOOSING AN ENCLOSURE

To get the best performance from your subwoofer, you must mount it inside an enclosure. An enclosure makes your subwoofer more efficient and improves its sound quality.

Some common enclosure designs are:

- Acoustic suspension (sealed)
- Ported reflex (vented)
- Single reflex bandpass (vented)

For more information about a single reflex bandpass enclosure, see "Single Reflex Bandpass (vented)" on Page 2.

To learn more about and build an acoustic suspension or ported reflex enclosure, we recommend you use the book *Building Speaker Systems* (Cat. No. 62-1087A, available at your local RadioShack store) along with this Owner's Manual. That book has complete information about building enclosures, including obtaining construction materials, and design and construction tips.

**Note:** Check with RadioShack Unlimited for a pre-built enclosure for this subwoofer.

### ENCLOSURE SIZES

After you choose an enclosure type for your subwoofer, for the best results, build the enclosure to the dimensions recommended in this section.

#### Acoustic Suspension (sealed)

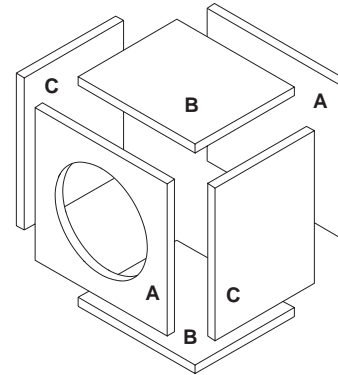

**13 × 13 × 9<sup>3</sup>/<sub>4</sub> Inches (HWD)**  
**.75 Cubic Feet (.47 net)**

**A (2) — 13" × 13" (one with 9<sup>1</sup>/<sub>16</sub>" diameter cutout)**  
**B (2) — 13" × 9<sup>3</sup>/<sub>4</sub>" HW**  
**C (2) — 11<sup>1</sup>/<sub>2</sub>" × 9<sup>3</sup>/<sub>4</sub>" HW**

**F3: 55 Hz**  
**Ripple: 0.07 dB**  
**Excursion Limited Power Handling: 200 Watts**

#### Ported Reflex (vented)

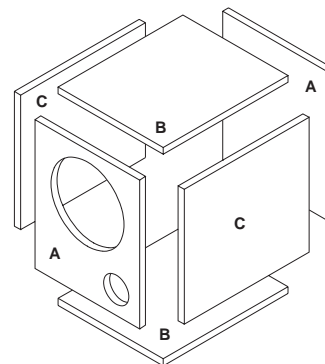

**13 × 16 × 15<sup>1</sup>/<sub>2</sub> Inches (HWD)**  
**1.5 Cubic Feet**

**A (2) — 13" × 16" (one with 9<sup>1</sup>/<sub>16</sub>" and 3" diameter cutout)**  
**B (2) — 13" × 15<sup>1</sup>/<sub>2</sub>" HW**  
**C (2) — 14<sup>1</sup>/<sub>2</sub>" × 15<sup>1</sup>/<sub>2</sub>" HW**

**Tuning Frequency: 38 Hz**  
**F3: 38Hz**  
**Ripple: 1.35 dB**  
**Excursion Limited Power Handling: 200 Watts**

## Single Reflex Bandpass (vented)

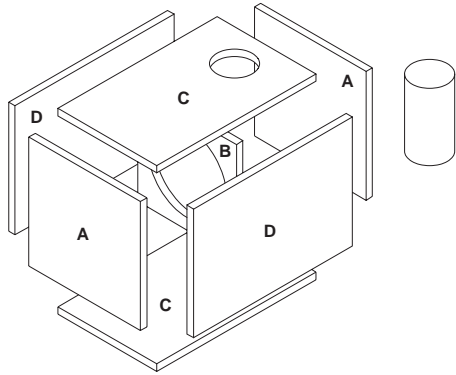

**13 × 11 × 20<sup>1</sup>/<sub>4</sub> Inches (HWD)**  
**1.36 Cubic Feet (.63 Sealed/.73 Vented)**  
**Inside Distance from Baffle to End Panel of Sealed Side of Enclosure — 8<sup>1</sup>/<sub>4</sub>"**

**A (2) — 13 × 13 Inches**  
**B (1) — 11<sup>1</sup>/<sub>2</sub> × 11<sup>1</sup>/<sub>2</sub>" (with 9<sup>1</sup>/<sub>16</sub>" diameter cutout)**  
**C (2) — 13" × 18<sup>1</sup>/<sub>2</sub>" HW (with cutout for 4 in. vent)**  
**D (2) — 11<sup>1</sup>/<sub>2</sub> × 18<sup>1</sup>/<sub>2</sub>" HW**

**Tuning Frequency: 70 Hz**  
**F3: 42–111 Hz**  
**Ripple: .29 dB**

**Excursion Limited Power Handling: 200 Watts**

A single reflex bandpass enclosure combines the features of acoustic suspension and ported reflex designs. In this type of enclosure, one side of the subwoofer is mounted in an acoustic suspension enclosure, while the other side is mounted in a ported reflex enclosure.

A single reflex bandpass enclosure controls the movement of the speaker's cone at low frequencies (like an acoustic suspension enclosure), and has the ability to sacrifice efficiency for deeper bass or vice versa. The frequency response of the single reflex bandpass enclosure is controlled by the volume of the enclosure.

Due to the complexity of its construction, a single reflex bandpass enclosure can be difficult to design and build. If you are inexperienced at building enclosures, we recommend that you build an acoustic suspension or ported reflex enclosure.

## CONNECTING THE SUBWOOFER TO YOUR STEREO AMPLIFIER

We recommend you use 12-gauge or thicker wire (such as Cat. No. 278-1268, not supplied) to connect the subwoofer to your stereo amplifier. For the maximum bass response and the best overall performance, be sure to connect + to + and – to –.

**Note:** You can mount an optional speaker plate on your enclosure (such as Cat. No. 274-630) to make it easy to connect the subwoofer to your stereo amplifier. This lets you connect the subwoofer to the plate, then connect the plate to your stereo amplifier.

Follow these steps to connect the subwoofer directly to your sound system.

1. Run one wire from each of the subwoofer's terminals to the stereo amplifier.
2. Separate each wire's two conductors at both ends for a length of about 2 inches, then strip the insulation from the ends of each conductor to expose 1/2 inch of wire.

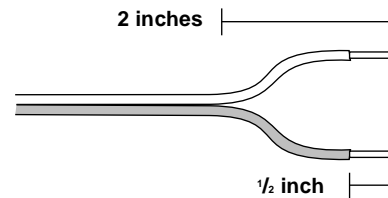

3. Twist the endcap from a banana plug (not supplied) to remove it, route one of the speaker's wires through the endcap, then fold the exposed wire around the top of the endcap.



4. Twist the banana plug back onto the endcap as shown here.

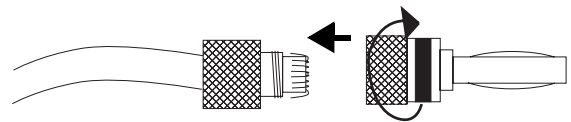

5. Repeat Steps 3 and 4 for each of the subwoofer's wires.
6. Press the banana plugs into the subwoofer's terminals to connect them.

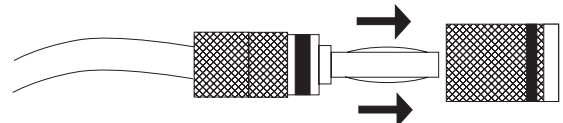

## FREQUENCY RESPONSE

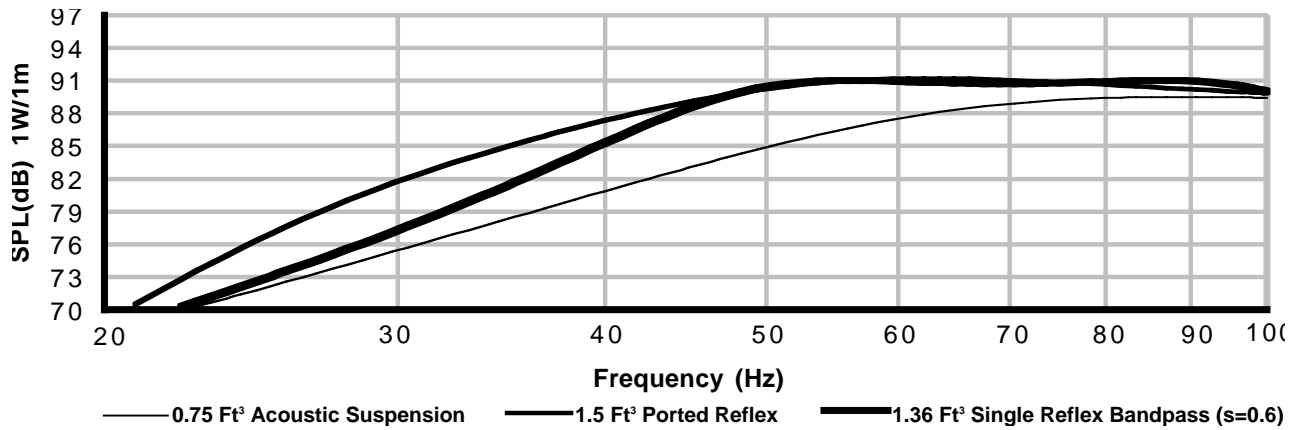

## SPECIFICATIONS

Frequency Range .....	38–150 Hz
Resonant Frequency .....	37.8 Hz
Power Handling .....	200 Watts RMS/400 Watts Max
Nominal Impedance .....	4 Ohms
Piston Area .....	55.1 In <sup>2</sup> , .0356 M <sup>2</sup>
Magnet Weight .....	25 oz
Flux Density .....	10.25 Tm
DC Voice Coil Resistance .....	3.35 Ohms
Voice Coil Inductance .....	2.14 mH
Total Q Factor .....	.58 Qts
Electrical Q Factor .....	.61 Qes
Mechanical Q Factor .....	11.78 Qms
Equivalent Acoustic Volume .....	1.37 Ft <sup>3</sup>
Mechanical Suspension Compliance .....	.219 mm/N
Mechanical Mass of Cone Assembly and Free Air Load .....	80.9 g
Mechanical Mass of Cone Assembly only .....	77.0 g
Peak to Peak (maximum) Linear Excursion .....	.7187 In
Sensitivity .....	87.9 dB (1 Watt @ 1 Meter)
Cone .....	10 Inches, Wet Look Treated Fiber
Voice Coil .....	1.5 Inches, Kapton MTB Former
Surround (material of construction) .....	Polyether Foam
Connectors .....	5-Way, Gold-Plated
Mounting Cutout .....	9 <sup>1</sup> / <sub>16</sub> Inches (22.93 cm)
Mounting Depth .....	4 <sup>7</sup> / <sub>8</sub> Inches (12.42 cm)

Specifications are typical; individual units might vary. Specifications are subject to change and improvement without notice.

### Limited Ninety-Day Warranty

This product is warranted by RadioShack against manufacturing defects in material and workmanship under normal use for ninety (90) days from the date of purchase from RadioShack company-owned stores and authorized RadioShack franchisees and dealers. EXCEPT AS PROVIDED HEREIN, RadioShack MAKES NO EXPRESS WARRANTIES AND ANY IMPLIED WARRANTIES, INCLUDING THOSE OF MERCHANTABILITY AND FITNESS FOR A PARTICULAR PURPOSE, ARE LIMITED IN DURATION TO THE DURATION OF THE WRITTEN LIMITED WARRANTIES CONTAINED HEREIN. EXCEPT AS PROVIDED HEREIN, RadioShack SHALL HAVE NO LIABILITY OR RESPONSIBILITY TO CUSTOMER OR ANY OTHER PERSON OR ENTITY WITH RESPECT TO ANY LIABILITY, LOSS OR DAMAGE CAUSED DIRECTLY OR INDIRECTLY BY USE OR PERFORMANCE OF THE PRODUCT OR ARISING OUT OF ANY BREACH OF THIS WARRANTY, INCLUDING, BUT NOT LIMITED TO, ANY DAMAGES RESULTING FROM INCONVENIENCE, LOSS OF TIME, DATA, PROPERTY, REVENUE, OR PROFIT OR ANY INDIRECT, SPECIAL, INCIDENTAL, OR CONSEQUENTIAL DAMAGES, EVEN IF RadioShack HAS BEEN ADVISED OF THE POSSIBILITY OF SUCH DAMAGES.

Some states do not allow the limitations on how long an implied warranty lasts or the exclusion of incidental or consequential damages, so the above limitations or exclusions may not apply to you.

In the event of a product defect during the warranty period, take the product and the RadioShack sales receipt as proof of purchase date to any RadioShack store. RadioShack will, at its option, unless otherwise provided by law: (a) correct the defect by product repair without charge for parts and labor; (b) replace the product with one of the same or similar design; or (c) refund the purchase price. All replaced parts and products, and products on which a refund is made, become the property of RadioShack. New or reconditioned parts and products may be used in the performance of warranty service. Repaired or replaced parts and products are warranted for the remainder of the original warranty period. You will be charged for repair or replacement of the product made after the expiration of the warranty period.

This warranty does not cover: (a) damage or failure caused by or attributable to acts of God, abuse, accident, misuse, improper or abnormal usage, failure to follow instructions, improper installation or maintenance, alteration, lightning or other incidence of excess voltage or current; (b) any repairs other than those provided by a RadioShack Authorized Service Facility; (c) consumables such as fuses or batteries; (d) cosmetic damage; (e) transportation, shipping or insurance costs; or (f) costs of product removal, installation, set-up service adjustment or reinstallation.

This warranty gives you specific legal rights, and you may also have other rights which vary from state to state.

RadioShack Customer Relations, Dept. W, 100 Throckmorton St., Suite 600, Fort Worth, TX 76102

*We Service What We Sell*

3/97

**RadioShack**  
**A Division of Tandy Corporation**  
**Fort Worth, Texas 76102**